

Earless flanged ceramic package; 4 leads

SOT1214B

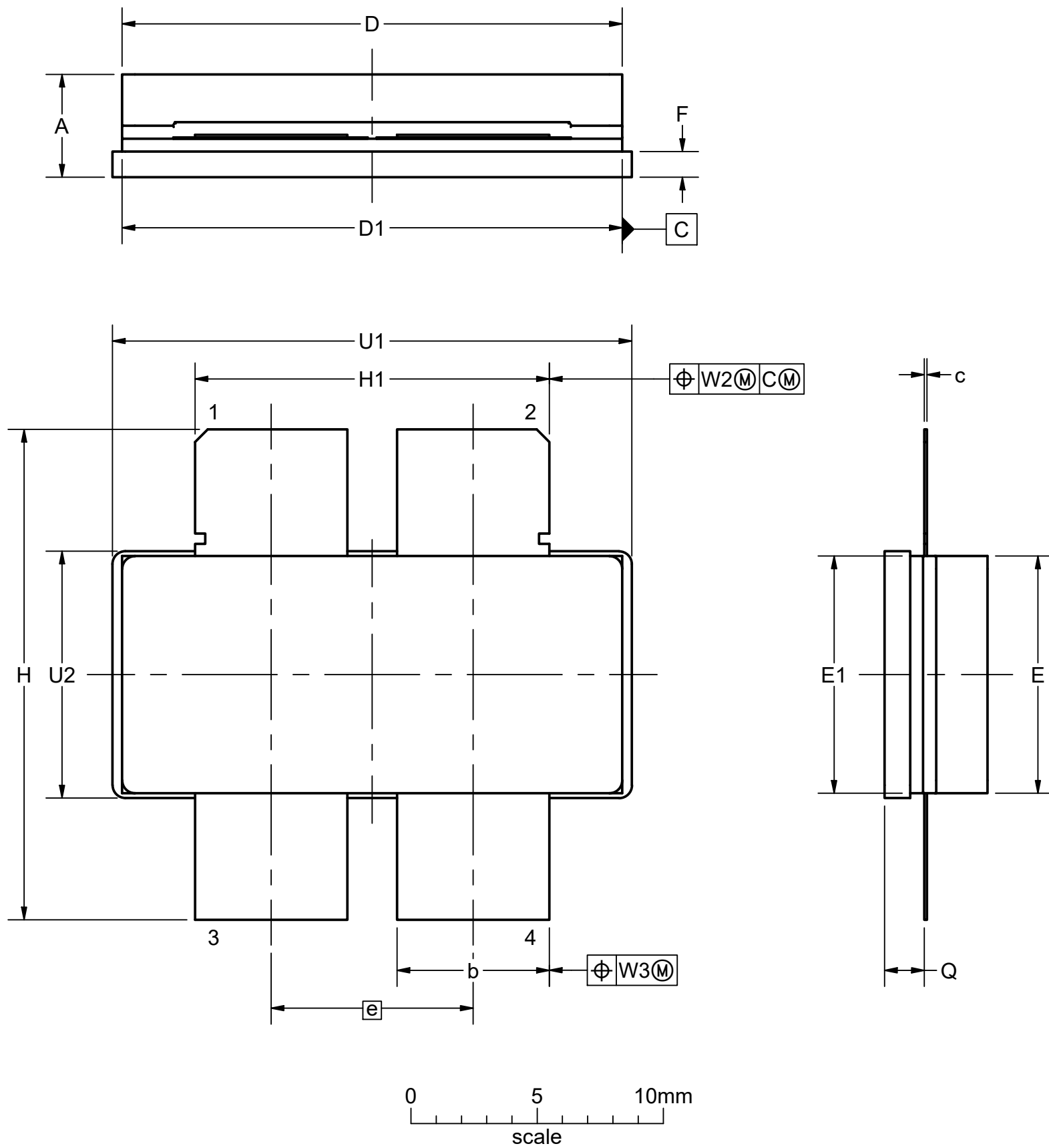

Dimensions

Unit (1)	A	b	c	D	D1	e	E	E1	F	H	H1	Q(2)	U1	U2	w2	w3
mm	max	4.72	6.17	0.15	20.02	19.96		9.53	9.50	1.14	19.94	1.70	20.70	9.91		
	nom						8.21				14.24				0.51	0.25
	min	3.43	5.92	0.08	19.61	19.66		9.27	9.29	0.89	18.92	1.45	20.45	9.65		
inches	max	0.187	0.243	0.006	0.788	0.786		0.375	0.374	0.045	0.785	0.067	0.815	0.39		
	nom						0.323				0.56				0.02	0.01
	min	0.135	0.233	0.003	0.772	0.774		0.365	0.366	0.035	0.745	0.057	0.805	0.38		

Note

1. millimeter dimensions are derived from the original inch dimensions.
2. dimension is measured 0.030 inch (0.76) from body.

sot1214b\_po

Outline version	References			European projection	Issue date
	IEC	JEDEC	JEITA		
SOT1214B					14-03-27 24-05-16

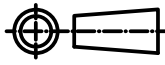
Drawing Notes			
Items	Description		
(1)	Millimeter dimensions are derived from the original inch dimensions.		
(2)	Dimension is measured 0.030 inch (0.76) from the body.		
Package outline drawing:		units in mm.	Tolerances unless otherwise stated: Dimension: $\pm 0.127$ Angle: $\pm 1^\circ$
SOT1214B Publication		 Third angle projection	Revision: 4 Revision date: 5/16/2024
			Sheet 2 of 2