

AR211048

ART150FE, 128 MHz

v1.0 – March 15, 2021

AMPLEON

Application Report

Document information

Status v1.0

Abstract Measurement results of a demoboard design with the ART150FE at 128 MHz

1. Revision History

Table 1 – Report revisions

Revision	Date	Description	Author
1.0	2021.03.15	Initial document	

2. Contents

1.	Revision History.....	2
2.	Contents.....	2
3.	List of figures.....	2
4.	List of tables.....	2
5.	General description.....	3
6.	CW RF characteristics.....	4
7.	CW Performance Details.....	4
8.	Harmonic Rejection.....	5
9.	Thermal picture.....	6
10.	User Guide.....	7
10.1	Biasing.....	7
10.2	Bill of Materials.....	8
10.3	Device markings.....	9
11.	Legal information.....	10
11.1	Definitions.....	10
11.2	Disclaimers.....	10
11.3	Trademarks.....	10
11.4	Contact information.....	10

3. List of figures

Figure 1 – Demo front view.....	3
Figure 2 – CW performance.....	4
Figure 3 – Harmonics level measured during the output power sweep.....	5
Figure 4 – IR CW Thermal picture.....	6
Figure 5 – Board pin configuration.....	7
Figure 6 – Component mapping.....	8

4. List of tables

Table 1 – Report revisions.....	2
Table 2 – Test circuit information.....	3
Table 3 – Performance indication.....	4
Table 4 – RF Performance overview.....	4
Table 5 – Pin description.....	7
Table 6 – Bill of Materials.....	8
Table 7 – Module specifics.....	9

5. General description

This report presents the measurement results of the demoboard designed for 128 MHz using the ART150FE transistor based on 65V ART technology. During assembly, the PCB has been screwed down without soldering it and the connection of the transistor has been made with a pressing block. Thermally conductive paste has been put under the transistor to improve the thermal behavior.

The dedicated demo-circuit is matched to 50 Ω at input and output.

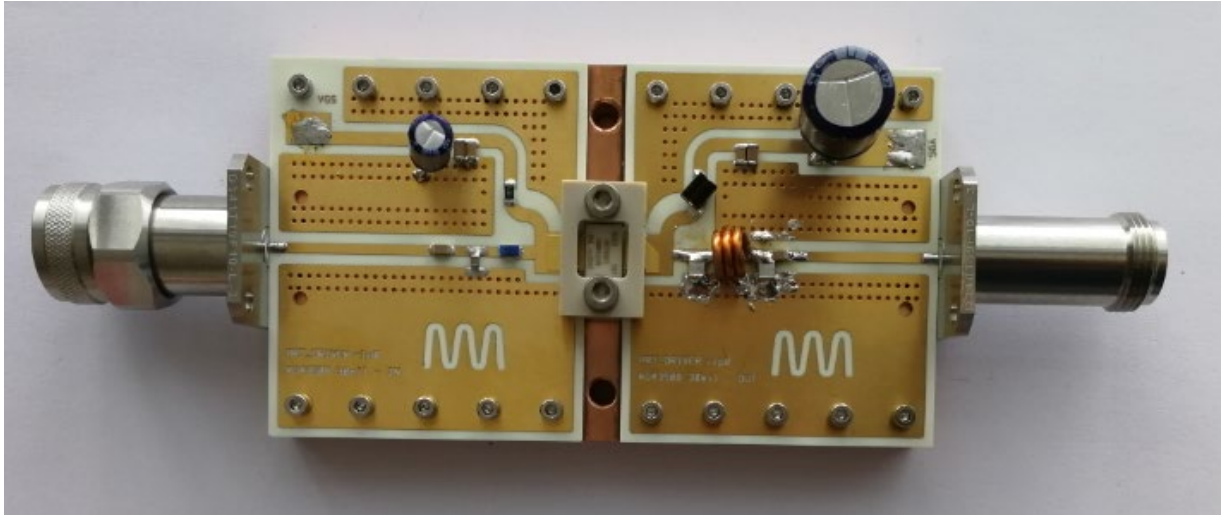

Figure 1 – Demo front view

Table 2 – Test circuit information

Parameter	Description	Unit
Laminate Type	Rogers 4350B	
Dk	3.48	
Df	0.0037 @10 GHz	
Laminate thickness	0.762	mm
Copper thickness	1 oz top/bottom	
Overall dimensions	106 x 60	mm
Cooling type	Indirect water cooling	
Device Package	SOT467	

6. CW RF characteristics

Table 3 – Performance indication

Test signal: CW; RF performance at $V_{DS}=65V$; $I_{Dq}=10mA$; $T_{cooling\ water}=25^{\circ}C$

Symbol	Parameter	Conditions	Typical	Unit
f	Frequency		128	MHz
V_{DS}	Drain-source voltage		65	V
V_{GS}	Gate-source voltage	$I_{Dq} = 10mA$	1.7	V
Gp	Power Gain	$P_{1dBcp}=148.8\ W$	29.7	dB
η_D	Drain Efficiency	$P_{1dBcp}=148.8\ W$	81.9	%

7. CW Performance Details

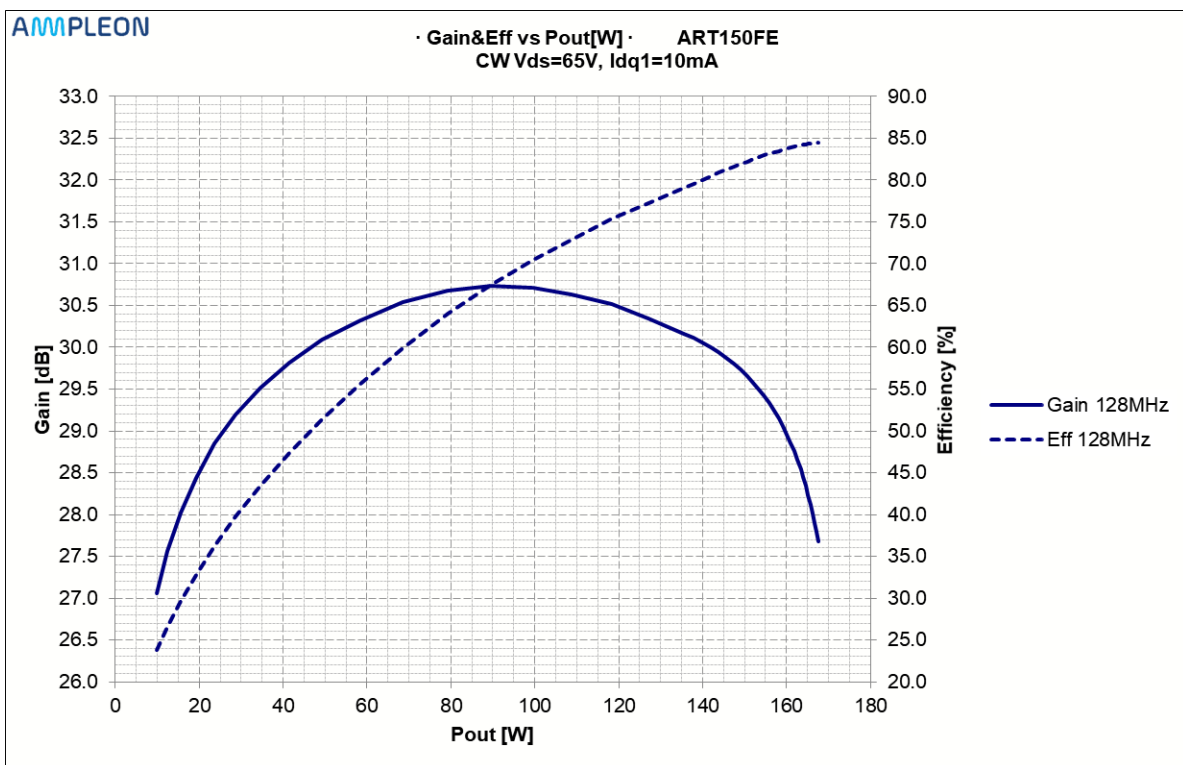

Figure 2 – CW performance

Table 4 – RF Performance overview

Freq [MHz]	Gmax [dB]	Pout@Gmax [W]	P1dB [W]	P2dB [W]	P3dB [W]	Effmax [%]	Pout@Effmax [W]	Eff P1dB [%]	Eff P2dB [%]	Eff P3dB [%]
128	30.74	89.56	148.84	161.98	167.32	84.45	167.57	81.88	84.01	84.44

8. Harmonic Rejection

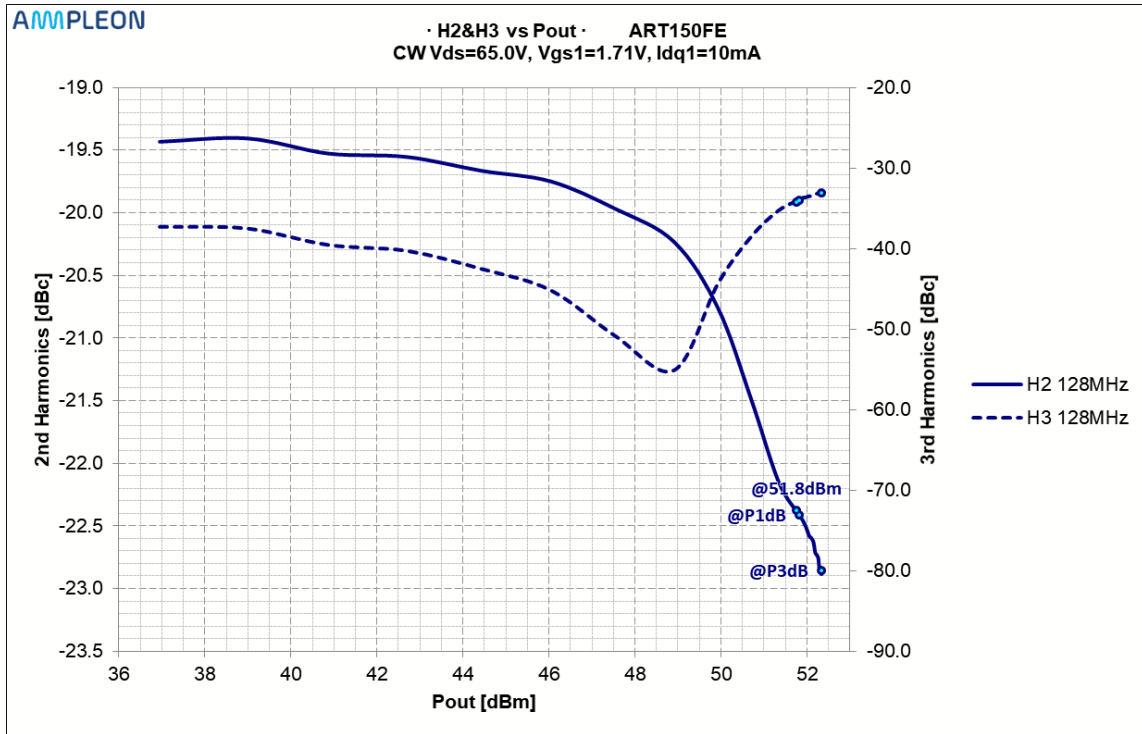

Figure 3 – Harmonics level measured during the output power sweep

9. Thermal picture

The board has been measured with an IR camera to detect hotspots. The hottest component is the output series inductor but the temperature is still at an acceptable level.

The following conditions have been applied:

- VDS=65V, Idq=10 mA
- Water temperature: 25 degC
- Signal Type: CW
- Output Power: 160W

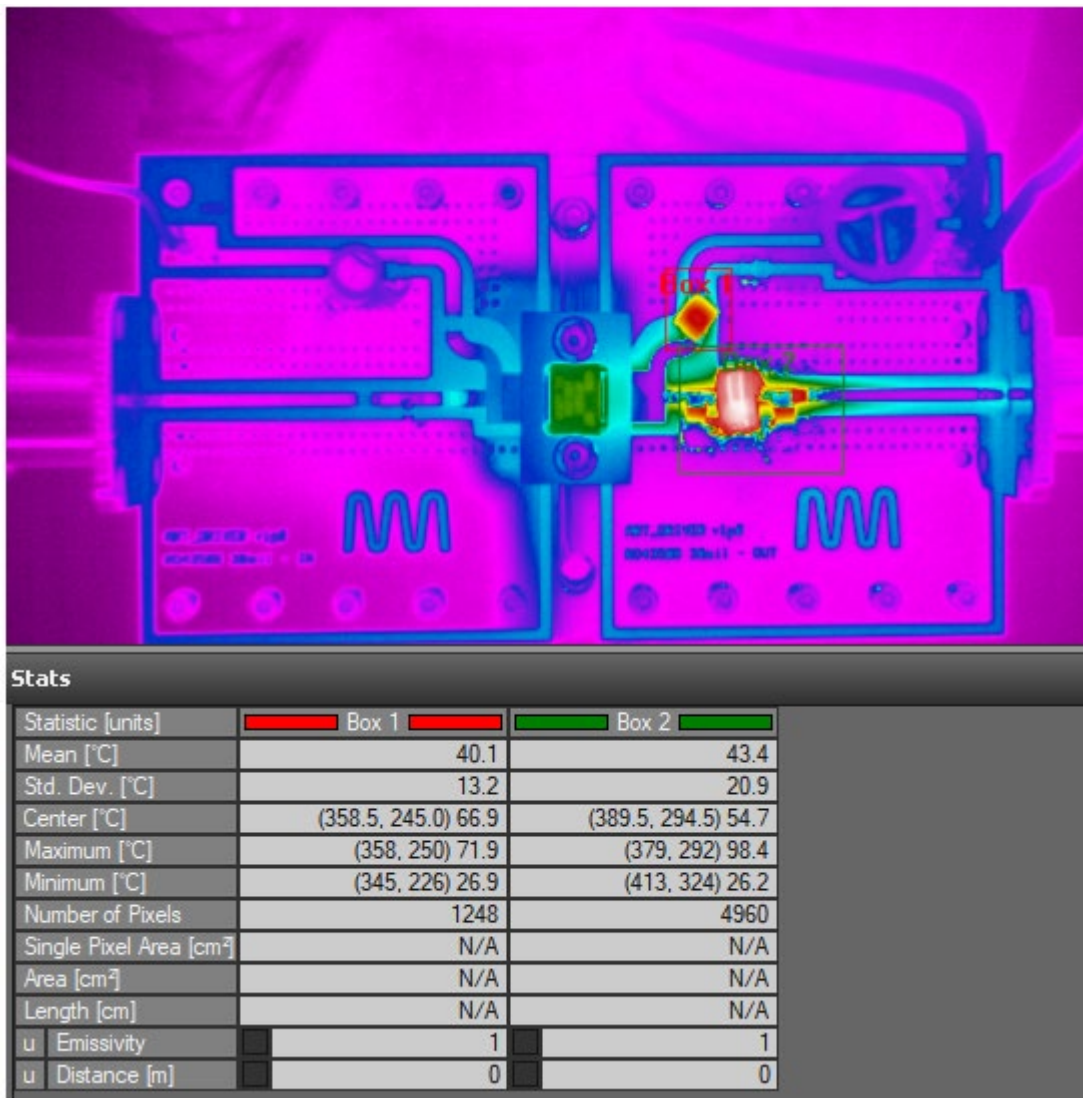

Figure 4 – IR CW Thermal picture

10. User Guide

10.1 Biasing

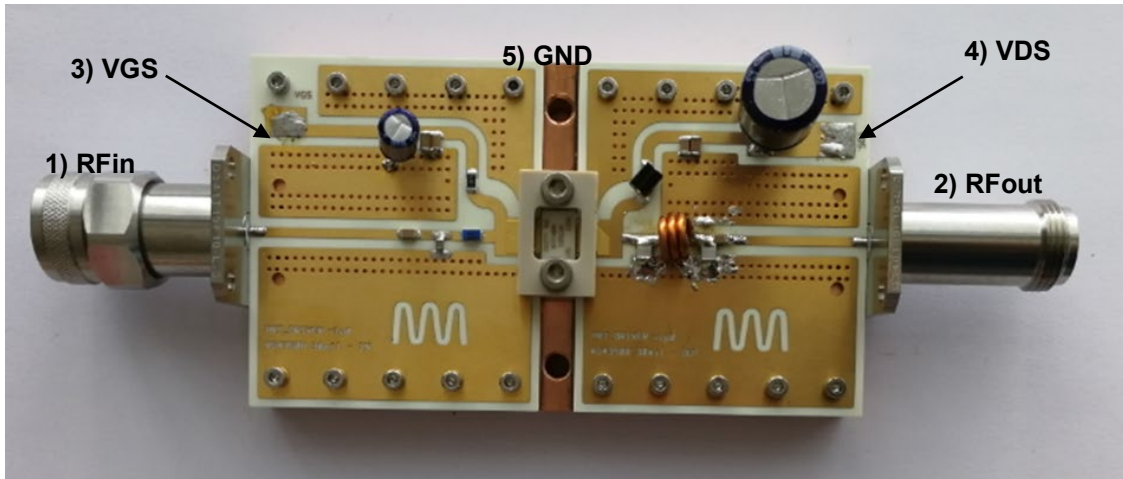

Figure 5 – Board pin configuration

Table 5 – Pin description

Symbol	Pin	Description
RF _{IN}	1	RF input
RF _{OUT}	2	RF output
V _{GS}	3	Gate-source voltage
V _{DS}	4	Drain-source voltage
GND	5	Negative supply terminal for V _{DS} and V _{GS}

10.2 Bill of Materials

Table 6 – Bill of Materials

Part	Description	Value	Remark
C1, C5, C6, C12	Multilayer ceramic chip capacitor	100 nF	100V
C2	Multilayer ceramic chip capacitor	91 pF	ATC800A
C3	Electrolytic capacitor	47uF	
C4, C7	Multilayer ceramic chip capacitor	4.7uF	100V
C8	Electrolytic capacitor	220 uF	100V
C10	Multilayer ceramic chip capacitor	20 pF	ATC800B
C11	Multilayer ceramic chip capacitor	51 pF	ATC800B
R1	Chip Resistor	5.1 kOhm	1206
L1	Chip inductor	27 nH	1206CS
L2	Chip inductor	100nH	1812SMS
L3	Air core inductor	3 turns, D=4.6 mm, Length=4.5 mm WireD=1.5mm	33 nH

*Remark: if more power is required from the demo the inductance can be lowered by choosing a smaller coil diameter

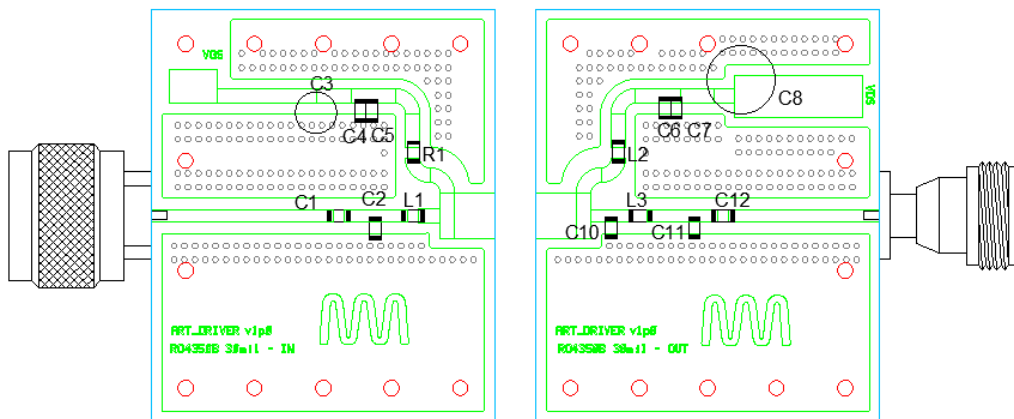

Figure 6 – Component mapping

10.3 Device markings

Table 7 – Module specifics

Parameter	Value
Manufacturer	Ampleon
Device	ART150FE
Comments	Engineering sample: wk2042 – 0023 - 027

11. Legal information

11.1 Definitions

Draft — The document is a draft version only. The content is still under internal review and subject to formal approval, which may result in modifications or additions. Ampleon does not give any representations or warranties as to the accuracy or completeness of information included herein and shall have no liability for the consequences of use of such information.

11.2 Disclaimers

Limited warranty and liability — Information in this document is believed to be accurate and reliable. However, Ampleon does not give any representations or warranties, expressed or implied, as to the accuracy or completeness of such information and shall have no liability for the consequences of use of such information. Ampleon takes no responsibility for the content in this document if provided by an information source outside of Ampleon.

In no event shall Ampleon be liable for any indirect, incidental, punitive, special or consequential damages (including - without limitation - lost profits, lost savings, business interruption, costs related to the removal or replacement of any products or rework charges) whether or not such damages are based on tort (including negligence), warranty, breach of contract or any other legal theory.

Notwithstanding any damages that customer might incur for any reason whatsoever, Ampleon's aggregate and cumulative liability towards customer for the products described herein shall be limited in accordance with the Terms and conditions of commercial sale of Ampleon.

Right to make changes — Ampleon reserves the right to make changes to information published in this document, including without limitation specifications and product descriptions, at any time and without notice. This document supersedes and replaces all information supplied prior to the publication hereof.

Suitability for use — Ampleon products are not designed, authorized or warranted to be suitable for use in life support, life-critical or safety-critical systems or equipment, nor in applications where failure or malfunction of an Ampleon product can reasonably be expected to result in personal injury, death or severe property or environmental damage. Ampleon and its suppliers accepts no liability for inclusion and/or use of Ampleon products in

such equipment or applications and therefore such inclusion and/or use is at the customer's own risk.

Applications — Applications that are described herein for any of these products are for illustrative purposes only. Ampleon makes no representation or warranty that such applications will be suitable for the specified use without further testing or modification.

Customers are responsible for the design and operation of their applications and products using Ampleon products, and Ampleon accepts no liability for any assistance with applications or customer product design. It is customer's sole responsibility to determine whether the Ampleon product is suitable and fit for the customer's applications and products planned, as well as for the planned application and use of customer's third party customer(s). Customers should provide appropriate design and operating safeguards to minimize the risks associated with their applications and products.

Ampleon does not accept any liability related to any default, damage, costs or problem which is based on any weakness or default in the customer's applications or products, or the application or use by customer's third party customer(s). Customer is responsible for doing all necessary testing for the customer's applications and products using Ampleon products in order to avoid a default of the applications and the products or of the application or use by customer's third party customer(s). Ampleon does not accept any liability in this respect.

Export control — This document as well as the item(s) described herein may be subject to export control regulations. Export might require a prior authorization from competent authorities.

11.3 Trademarks

Notice: All referenced brands, product names, service names and trademarks are the property of their respective owners.

Any reference or use of any 'NXP' trademark in this document or in or on the surface of Ampleon products does not result in any claim, liability or entitlement vis-à-vis the owner of this trademark. Ampleon is no longer part of the NXP group of companies and any reference to or use of the 'NXP' trademarks will be replaced by reference to or use of Ampleon's own trademarks.

11.4 Contact information

For more information, please visit: <http://www.ampleon.com>

For sales office addresses, please visit: <http://www.ampleon.com/sales>