

Document information

Info	Content
Keywords	BLF574, 600 MHz performance, high voltage LDMOS, amplifier implementation, Class-B CW, FM band, pulsed power
Abstract	This application note describes the design and the performance of the BLF574 for Class-B CW and FM type applications in the 88 MHz to 108 MHz frequency range.

Revision history

Rev	Date	Description
02	20150901	Modifications <ul style="list-style-type: none">• The format of this document has been redesigned to comply with the new identity guidelines of Ampleon.• Legal texts have been adapted to the new company name where appropriate.
01	20100126	Initial version

1. Introduction

The BLF574 is a new, 50 V, push-pull transistor using Ampleon's 6th generation of high voltage LDMOS technology. The two push-pull sections of the device are completely independent of each other inside the package. The gates of the device are internally protected by the integrated ElectroStatic Discharge (ESD) diode.

The device is unmatched and is designed for use in applications below 600 MHz where very high power and efficiency are required. Typical applications are FM/VHF broadcast, laser or Industrial Scientific and Medical (ISM) applications.

Great care has been taken during the design of the high voltage process to ensure that the device achieves high ruggedness. This is a critical parameter for successful broadcast operations. The device can withstand greater than a 10 : 1 VSWR for all phase angles at full operating power.

Another design goal was to minimize the size of the application circuit. This is important in that it allows amplifier designers to maximize the power in a given amplifier size. The design highlighted in this application note achieves over 600 W in the 88 MHz to 108 MHz band in a space smaller than 50.8 mm × 101.6 mm (2 " × 4 "). The circuit only needs to be as wide as the transistor itself, enabling transistor mounting in the final amplifier to be as close as physically possible while still providing adequate room for the circuit implementation.

This application note describes the design and the performance of the BLF574 for Class-B CW and FM type applications in the 88 MHz to 108 MHz frequency band.

2. Circuit diagrams and PCB layout

2.1 Circuit diagrams

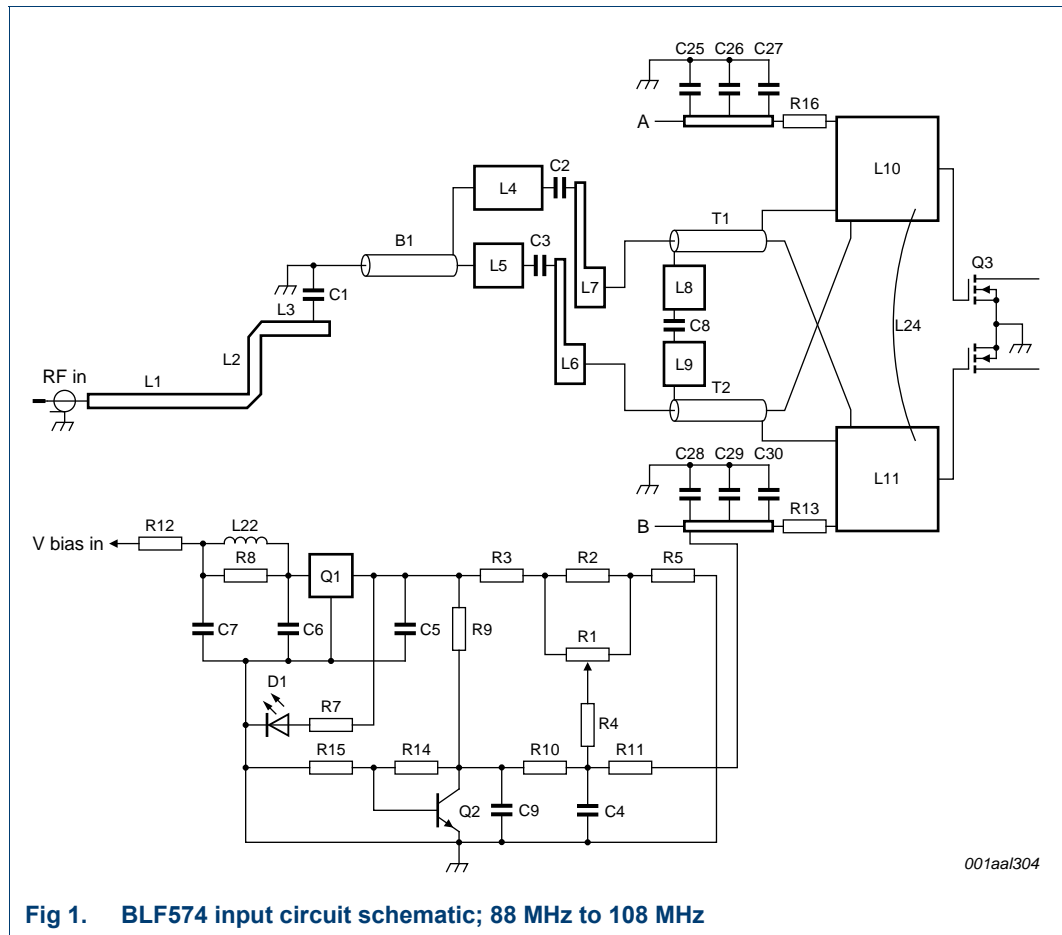
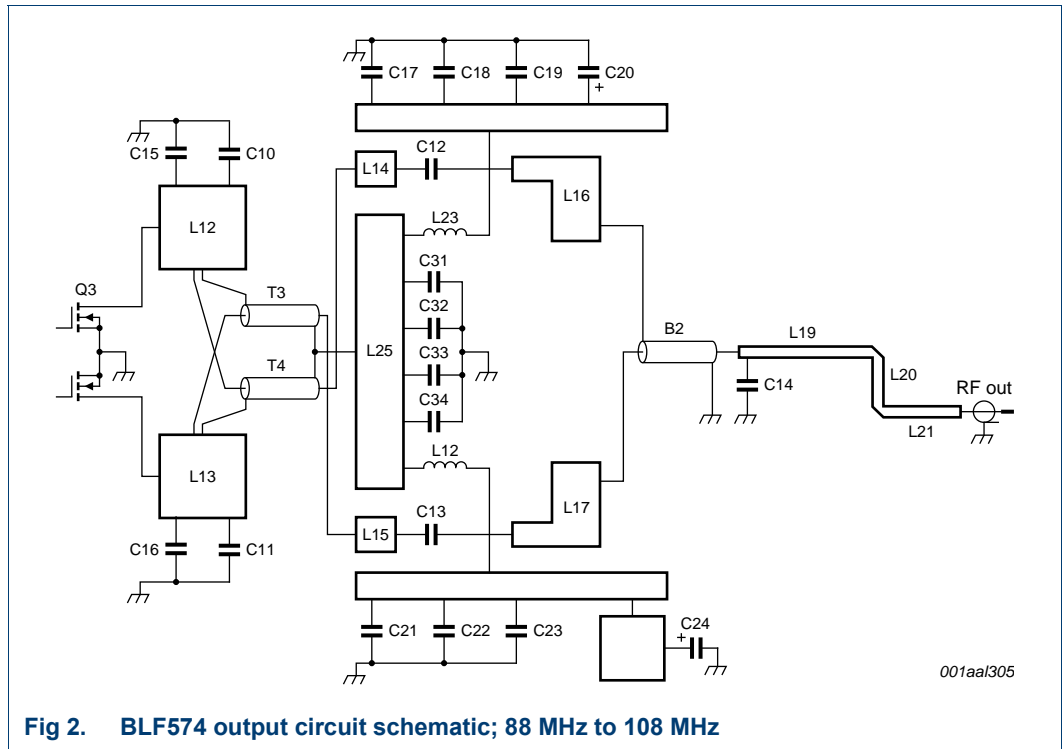
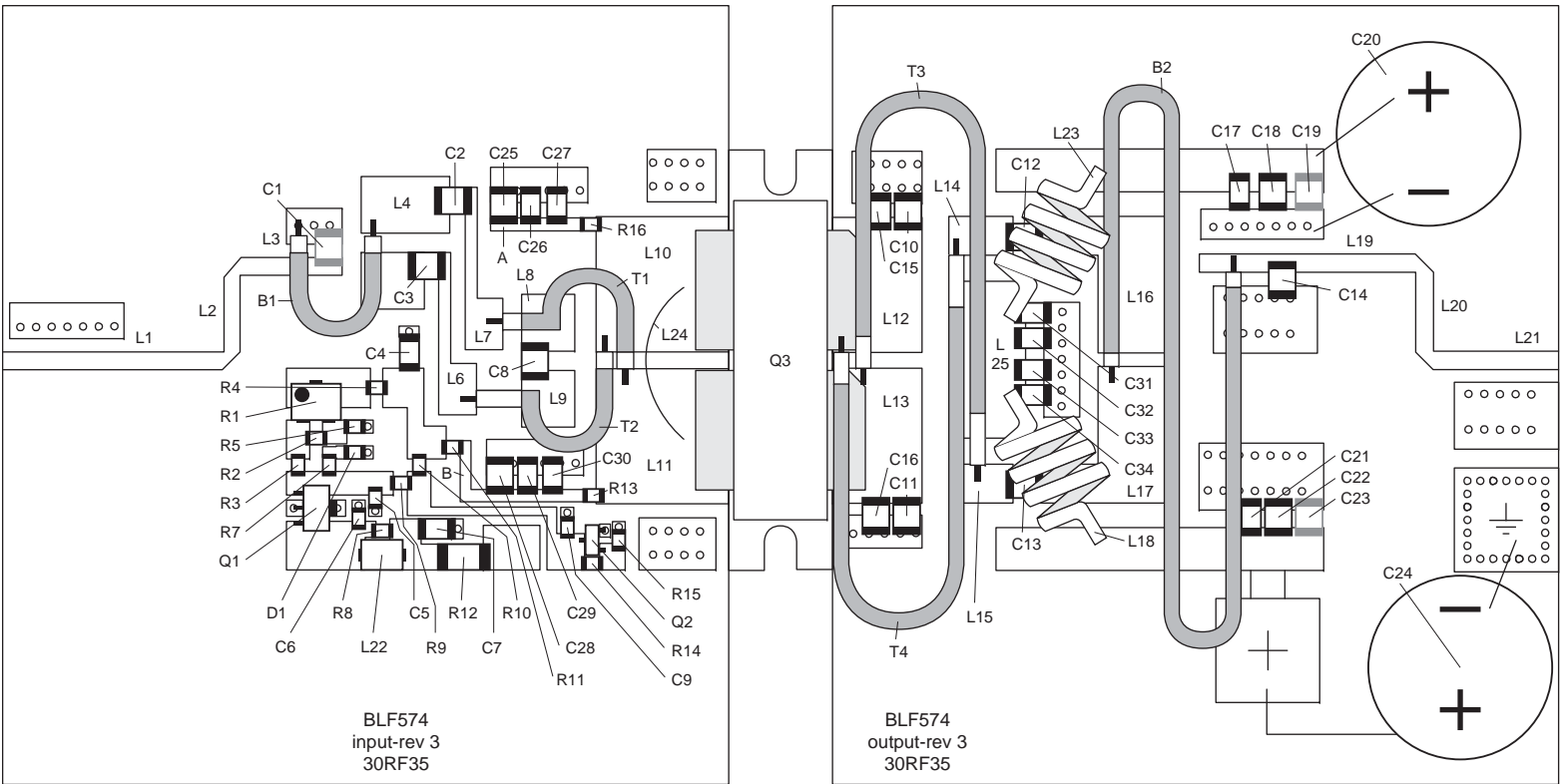

Fig 1. BLF574 input circuit schematic; 88 MHz to 108 MHz



2.2 BLF574 PCB layout



001aal306

The positions of C1, C19 and C23 are indicated but these capacitors are not connected.

Fig 3. BLF574 PCB layout

2.3 Bill Of Materials

Table 1. Bill of materials for the BLF574 input and output circuits

PCB material: Taconic RF35; $\epsilon_r = 3.5$; thickness 0.76 mm (30 mil). [Figure 3](#) shows the BLF574 PCB layout.

Designator	Description	Part number	Manufacturer
B1	63.5 mm (2.5 ")/50 Ω semirigid through ferrite ^[1]	ferrite: BN-61-202	Amidon
		semirigid: 047-50	Micro-Coax
B2	coax cable; 124.5 mm (4.9 ")/50 Ω ; ID = 3.5814 mm (0.141 ")	UT-141C-Form-F	Micro-Coax
C1	not connected	-	-
C2, C3	4700 pF ceramic chip capacitor	ATC700B472KW50X	American Technical Ceramics
C4, C7, C26, C29	1 μ F ceramic chip capacitor	GRM31MR71H105KA88L	MuRata
C5, C6, C9	100 nF ceramic chip capacitor	GRM21BR71H104KA01L	MuRata
C8	620 pF ceramic chip capacitor	ATC100B621JT100X	American Technical Ceramics
C10, C11	390 pF ceramic chip capacitor	ATC100B220GT500X	American Technical Ceramics
C12, C13	180 pF ceramic chip capacitor	ATC100B181JT200X	American Technical Ceramics
C14	6.8 pF ceramic chip capacitor	ATC100B6R8CT500X	American Technical Ceramics
C15, C16	15 pF ceramic chip capacitor	ATC100B150JT500X	American Technical Ceramics
C17, C21, C31, C32	100 nF/250 V ceramic chip capacitor	GRM32DR72E104KW01L	MuRata
C18, C22, C33, C34	2.2 μ F/100 V ceramic chip capacitor	GRM32ER72A225KA35	MuRata
C19, C23	not connected	-	-
C20, C24	1000 μ F, 100 V electrolytic capacitor	EEV-TG1V102M	Panasonic
C25, C28	10 nF/35 V ceramic chip capacitor	GRM32ER7YA106KA12L	MuRata
C27, C30	100 nF ceramic chip capacitor	GRM31CR72E104KW03L	MuRata
D1	LED	APT2012CGCK	KingBright
L1	21.7 mm \times 1.75 mm (855 mil \times 69 mil)	-	-
L2	9.2 mm \times 1.65 mm (364 mil \times 65 mil)	-	-
L3	9.9 mm \times 1.75 mm (390 mil \times 69 mil)	-	-
L4, L5	6.2 mm \times 5.5 mm (243 mil \times 218 mil)	-	-
L6, L7	[2]	-	-
L8, L9	5.2 mm \times 5.54 mm (205 mil \times 218 mil)	-	-
L10, L11	13.0 mm \times 13.2 mm (511 mil \times 520 mil)	-	-
L12, L13	8.8 mm \times 13.2 mm (345 mil \times 520 mil)	-	-
L14, L15	8.83 mm \times 3.81 mm (348 mil \times 150 mil)	-	-
L16, L17	[2]	-	-
L18, L23	3 turns 14 gauge wire; ID = 7.9 mm (0.310 ")	-	-
L19	21.2 mm \times 1.75 mm (834 mil \times 69 mil)	-	-
L20	9.5 mm \times 1.82 mm (373 mil \times 72 mil)	-	-
L21	13.99 mm \times 1.7 mm (551 mil \times 65 mil)	-	-
L22	ferroxcube bead	2743019447	Fair Rite
L24	50.8 mm (2 "); 14 gauge wire; ID = 15.5 mm (0.61 ") ^[3]	-	-
L25	7.6 mm \times 15.3 mm (299 mil \times 604 mil)	-	-

Table 1. Bill of materials for the BLF574 input and output circuits ...continued

PCB material: Taconic RF35; $\epsilon_r = 3.5$; thickness 0.76 mm (30 mil). [Figure 3](#) shows the BLF574 PCB layout.

Designator	Description	Part number	Manufacturer
Q1	7808 voltage regulator	NJM#78L08UA-ND	NJR
Q2	SMT 2222 NPN transistor	PMBT2222	NXP Semiconductors
Q3	600 W LDMOST	BLF574	Ampleon
R1	200 Ω potentiometer	3214W-1-201E	Bourns
R2, R3	432 Ω resistor	CRCW0805432RFKEA	Vishay Dale
R4	2 k Ω resistor	CRCW08052K00FKTA	Vishay Dale
R5	75 Ω resistor	CRCW080575R0FKTA	Vishay Dale
R6	not connected	-	-
R7, R9	1.1 k Ω resistor	CRCW08051K10FKEA	Vishay Dale
R10	11 k Ω resistor	CRCW080511K0FKEA	Vishay Dale
R11	5.1 Ω resistor	CRCW08055R1FKEA	Vishay Dale
R12	499 Ω /0.25 W resistor	CRCW2010499RFKEF	Vishay Dale
R13, R16	9.1 Ω resistor	CRCW08059R09FKEA	Vishay Dale
R14	5.1 k Ω resistor	CRCW08055K10FKTA	Vishay Dale
R15	910 Ω resistor	CRCW0805909RFKTA	Vishay Dale
T1, T2	63.5 mm (2.5 ")/25 Ω semirigid through ferrite ^[1]	ferrite: BN-61-202 semirigid: 047-25	Amidon Micro-Coax
T3, T4	coax cable 86.36 mm (3.4 ")/25 Ω ; ID = 2.18 mm (0.086 ")	E22[1]STJ	Thermax

- [1] The semirigid cable length is defined in [Figure 4](#).
- [2] Contact your local Ampleon sales person for the artwork file containing the dimensions.
- [3] N-male connector mounted as close to the package as possible.

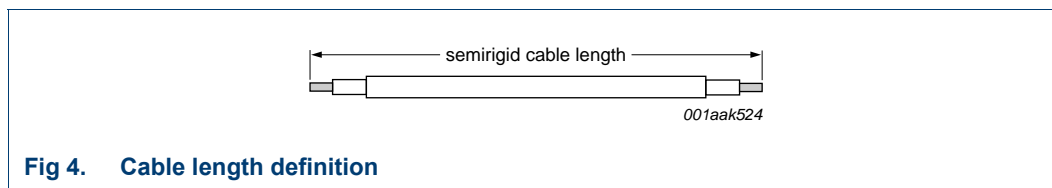

2.4 PCB form factor

Care has been taken to minimize board space for the design. [Figure 5](#) shows how 600 W can be generated in a space only as wide as the transistor itself.

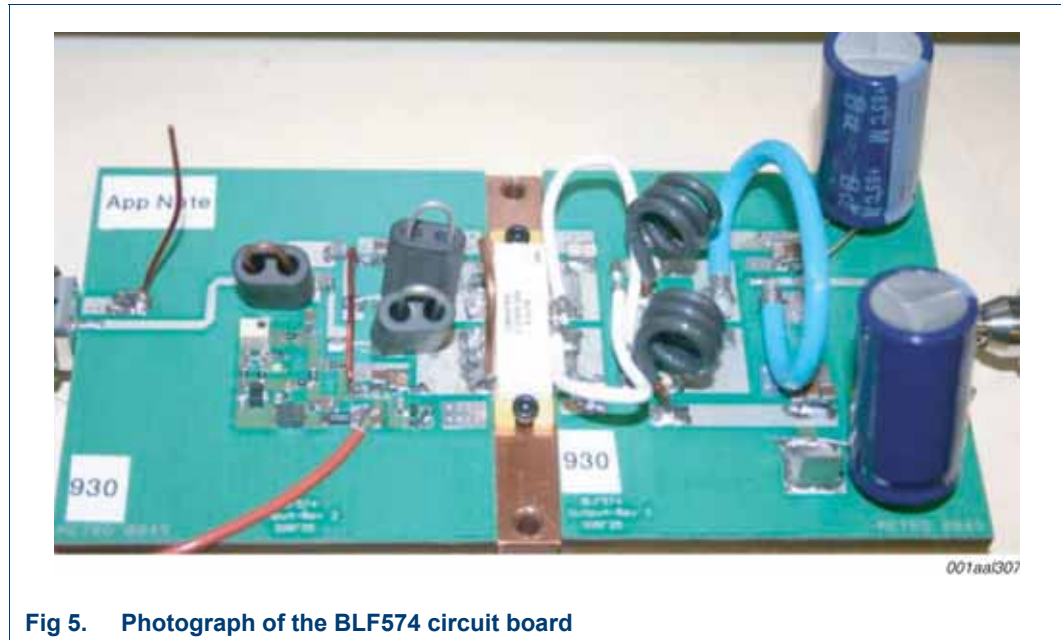

Fig 5. Photograph of the BLF574 circuit board

3. Amplifier design

3.1 Mounting considerations

To ensure good thermal contact, a heatsink compound (such as Dow Corning 340) should be used when mounting the BLF574 in the SOT539A package to the heatsink. Improved thermal contact is obtainable when the devices are soldered on to the heatsink. This lowers the junction temperature at high operating power and results in slightly better performance.

When greasing the part down, care must be taken to ensure that the amount of grease is kept to an absolute minimum. The Ampleon website can be consulted for application notes on the recommended mounting procedure for this type of device or from your local Ampleon salesperson.

3.2 Bias circuit

A temperature compensated bias circuit is used and comprises the following:

An 8 V voltage regulator (Q1) supplies the bias circuit. The temperature sensor (Q2) must be mounted in good thermal contact with the device under test (Q3). The quiescent current is set using a potentiometer (R1). The gate voltage correction is approximately $-4.8 \text{ mV}/^\circ\text{C}$ to $-5.0 \text{ mV}/^\circ\text{C}$. The V_{GS} range is also reduced using a resistor (R2).

The $-2.2 \text{ mV}/^\circ\text{C}$ at its base is generated by Q2. This is then multiplied by the R14 : R15 ratio for a temperature slope (i.e. approximately $-15 \text{ mV}/^\circ\text{C}$). The multiplication function provided by the transistor is the reason it is used rather than a diode. A portion of the $-15 \text{ mV}/^\circ\text{C}$ is applied to the potentiometer (R1).

The amount of temperature compensation is set by resistor R4. The ideal value of which proved to be $2 \text{ k}\Omega$. The values of R11 and R13 are not important for temperature compensation. However, they are used for baseband stability and to improve IMD asymmetry at lower power levels.

3.3 Amplifier alignment

There are several points in the circuit that allow performance parameters to be readily traded off against one another. In general, the following areas of the circuit have the most impact on the circuit operating frequency and $P_{L(1\text{dB})}$ performance. The modification areas are listed in order of sensitivity, with the most sensitive tuning elements listed first.

Effect of changing the output capacitors (C12 and C13):

- This is a key tuning point in the circuit. This point has the strongest influence on the trade-off between efficiency and linearity.

Effect of the length of the output balun (B2):

- The frequency can be shifted by modifying this element. Typically, the longer the balun, the more the response is shifted to lower frequencies. Conversely, a short balun shifts the response to higher frequencies.

Effect of changing the output 4 : 1 transformers (T3 and T4):

- The frequency can be shifted by modifying these elements. In general, longer transformers shift the whole response to a lower frequency. Shortening the transformers shifts the response to higher frequencies. Changes in efficiency and $P_{L(1\text{dB})}$ is seen when the characteristic impedance of these transformers is changed.

Effect of changing the output capacitor (C14):

- Changing this output capacitor has an effect of tilting the response over the band. The efficiency or $P_{L(1\text{dB})}$ performance can be made more consistent over the band by modifying C14.

Effect of adding capacitance off the drain (C10, C11, C15, and C16):

- A small adjustment in the trade-off between efficiency and $P_{L(1\text{dB})}$ performance can be made by changing these capacitors.

4. RF performance characteristics

4.1 Continuous wave

Table 2. Class-B performance of the BLF574 at 50 V/600 W

This table summarizes the Class-B performance of the BLF574 at 50 V, $I_{Dq} = 200$ mA and $T_h = 25$ °C.

Frequency (MHz)	P_L (W)	G_p (dB)	η (%)	RL (dB)
88	600	24.8	73.3	7.5
98	600	25.3	73.5	9
108	600	25.6	71.9	11.5

4.2 Continuous wave graphics

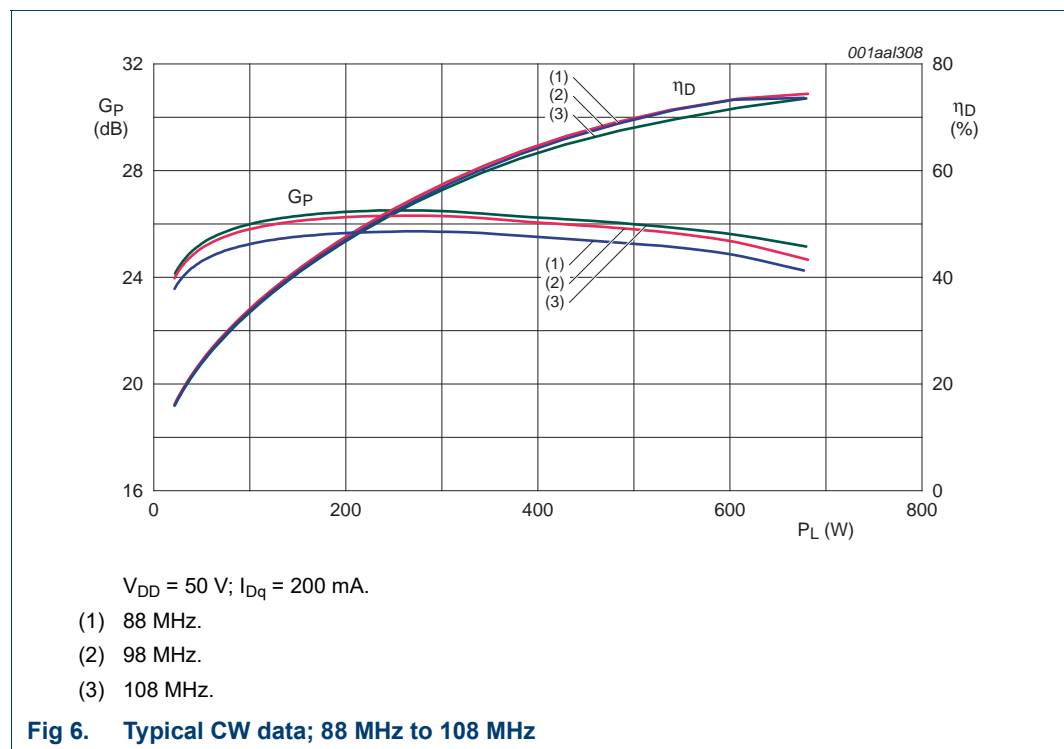

[Figure 7](#) shows the difference in gain and efficiency depending on the drain voltage conditions.

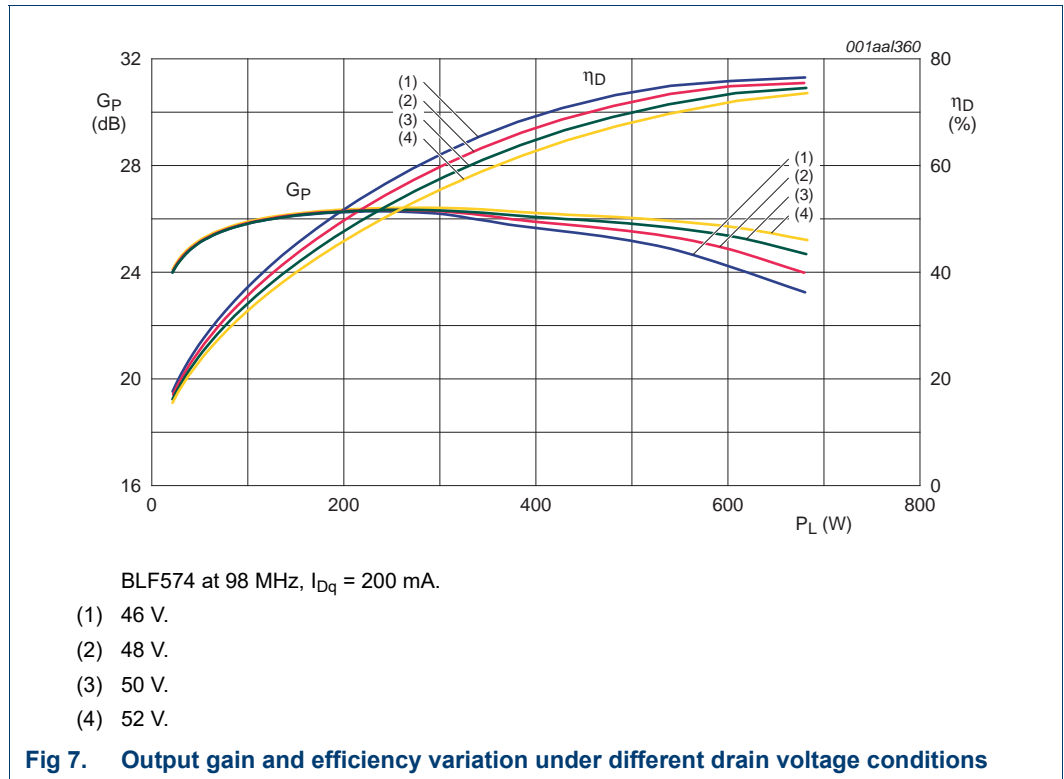

Figure 8 compares the performance of Class-B and Class-AB amplifier configurations.

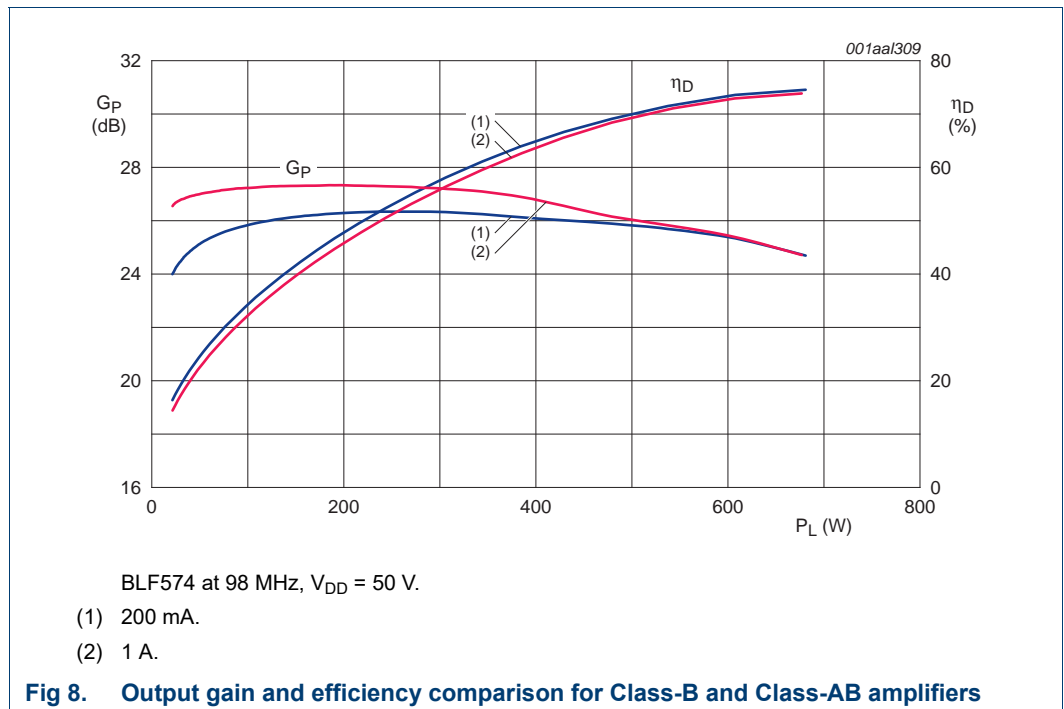
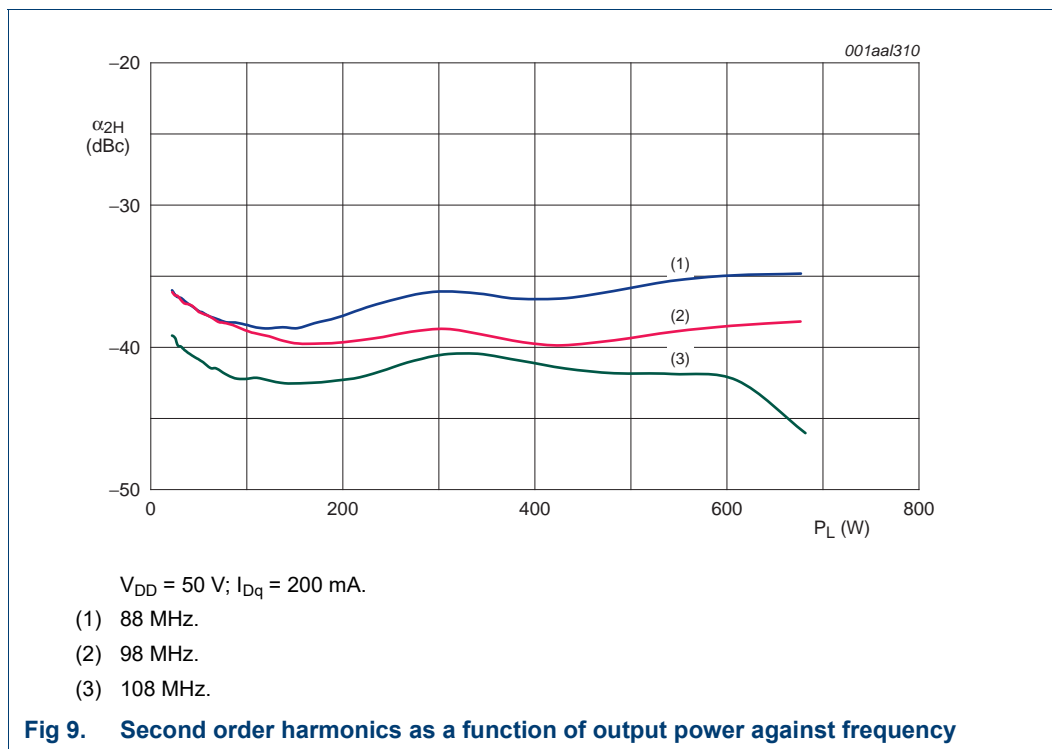

Figure 9 shows the second order harmonic performance.



5. Input and output impedance

The BLF574 input and output impedances are given in [Table 3](#). These are generated from a first order equivalent circuit of the device and can be used to get the first-pass matching circuits.

Table 3. Input and output impedance per section

Frequency (MHz)	Input (Z_i)	Output (Z_o)
25	2.020 – j26.216	4.987 – j0.241
50	2.020 – j13.087	4.947 – j0.477
75	2.020 – j8.701	4.882 – j0.705
100	2.020 – j6.500	4.794 – j0.922
125	2.021 – j5.175	4.685 – j1.125
150	2.021 – j4.286	4.559 – j1.310
175	2.022 – j3.647	4.418 – j1.478
200	2.023 – j3.164	4.266 – j1.626
225	2.023 – j2.768	4.106 – j1.755
250	2.024 – j2.480	3.941 – j1.864
275	2.025 – j2.227	3.773 – j1.955
300	2.026 – j2.014	3.605 – j2.028
325	2.028 – j1.832	3.439 – j2.084
350	2.029 – j1.673	3.275 – j2.126
375	2.030 – j1.534	3.116 – j2.154
400	2.032 – j1.410	2.962 – j2.170
425	2.033 – j1.299	2.814 – j2.176
450	2.035 – j1.199	2.673 – j2.172
475	2.037 – j1.108	2.538 – j2.159
500	2.039 – j1.025	2.410 – j2.140

The convention for these impedances is shown in [Figure 10](#). They indicate the impedances looking into half the device.

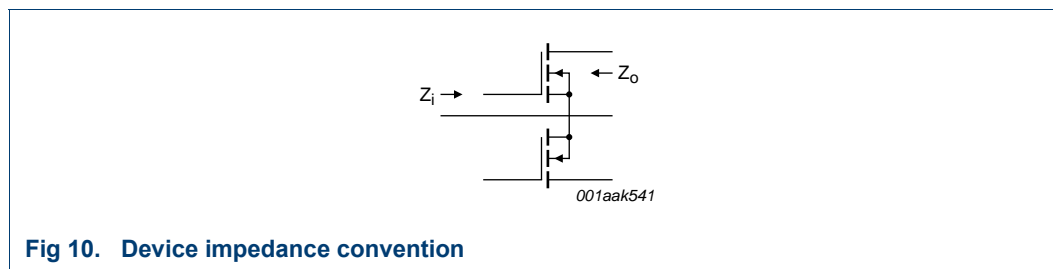

Fig 10. Device impedance convention

6. Base plate drawings

6.1 Input base plate

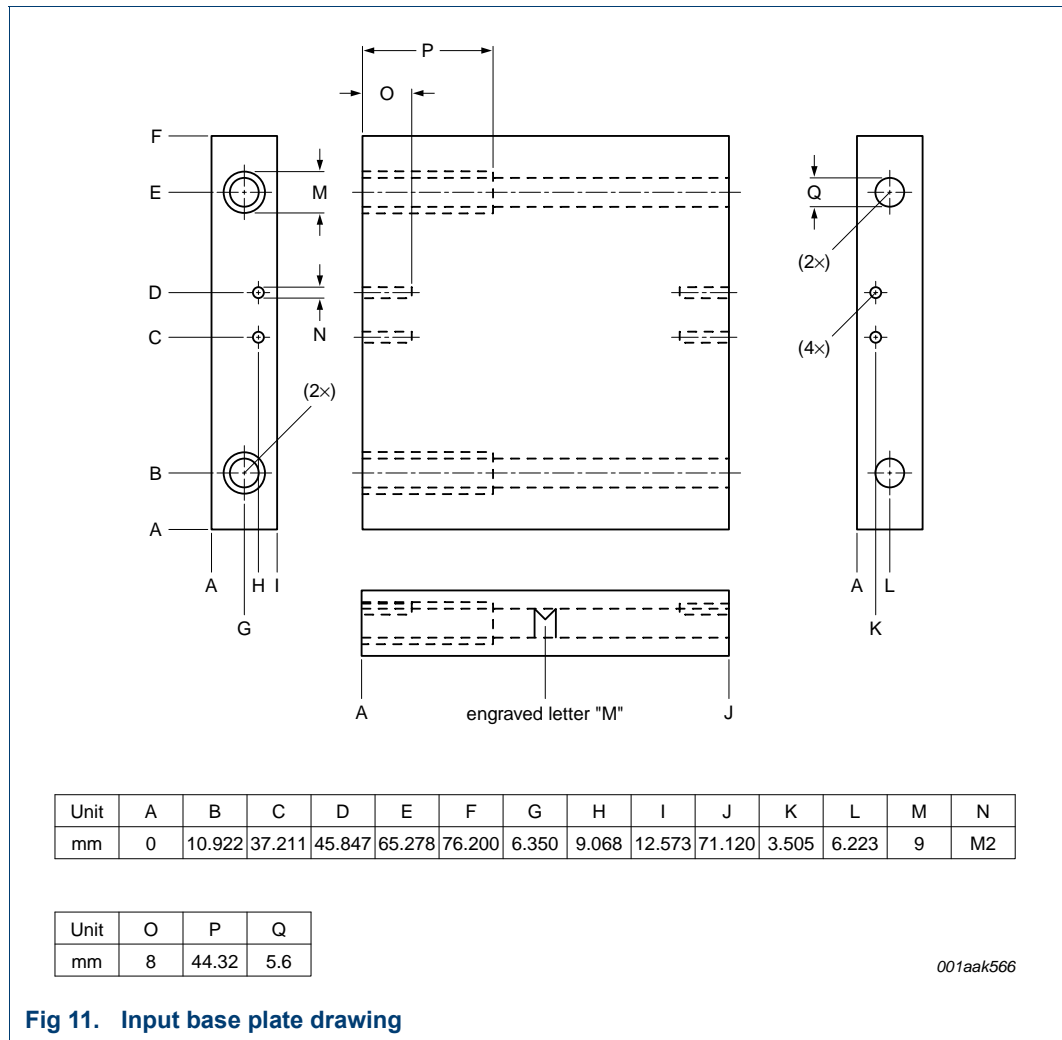
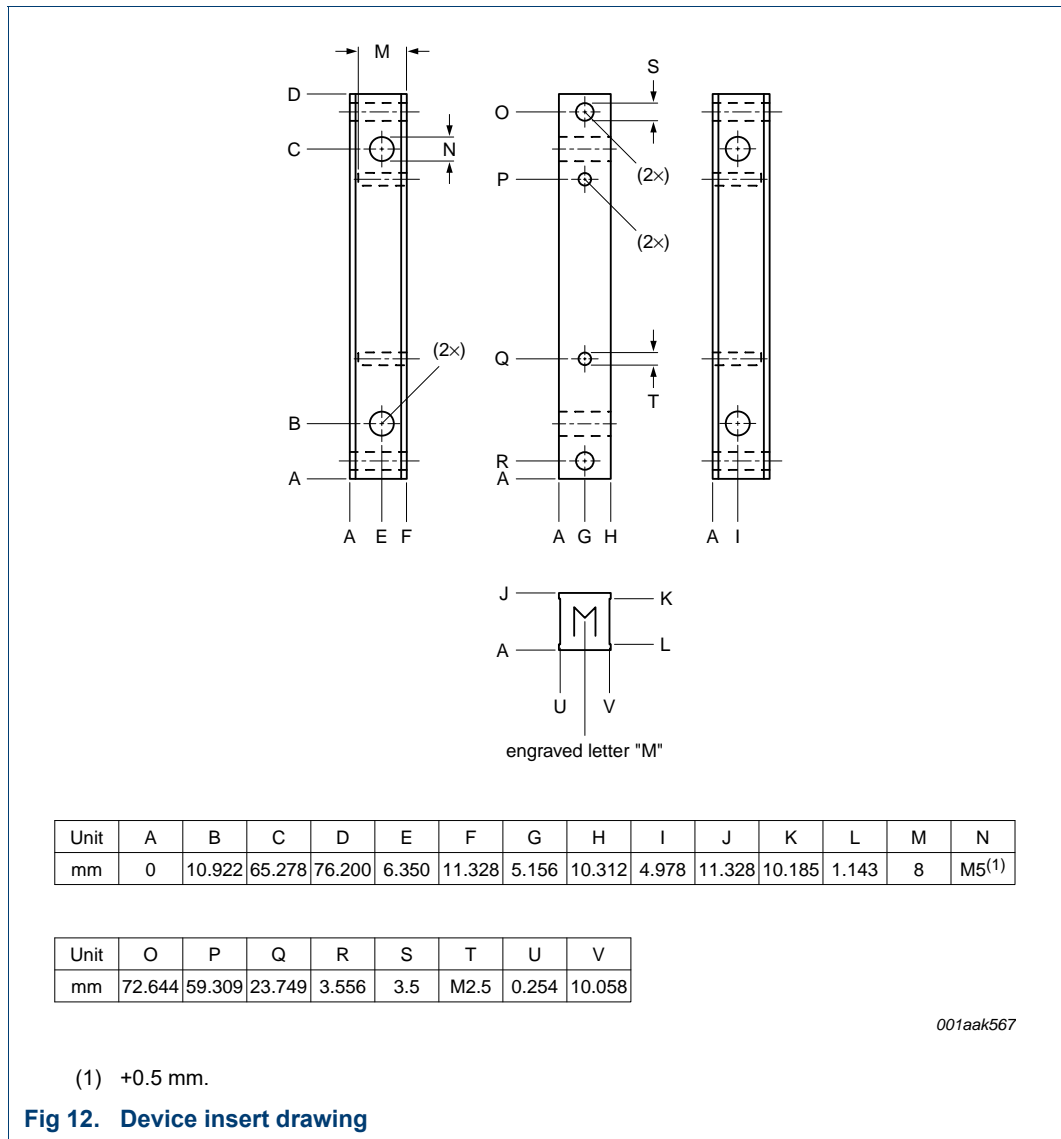

Fig 11. Input base plate drawing

6.2 Device insert



6.3 Output base plate

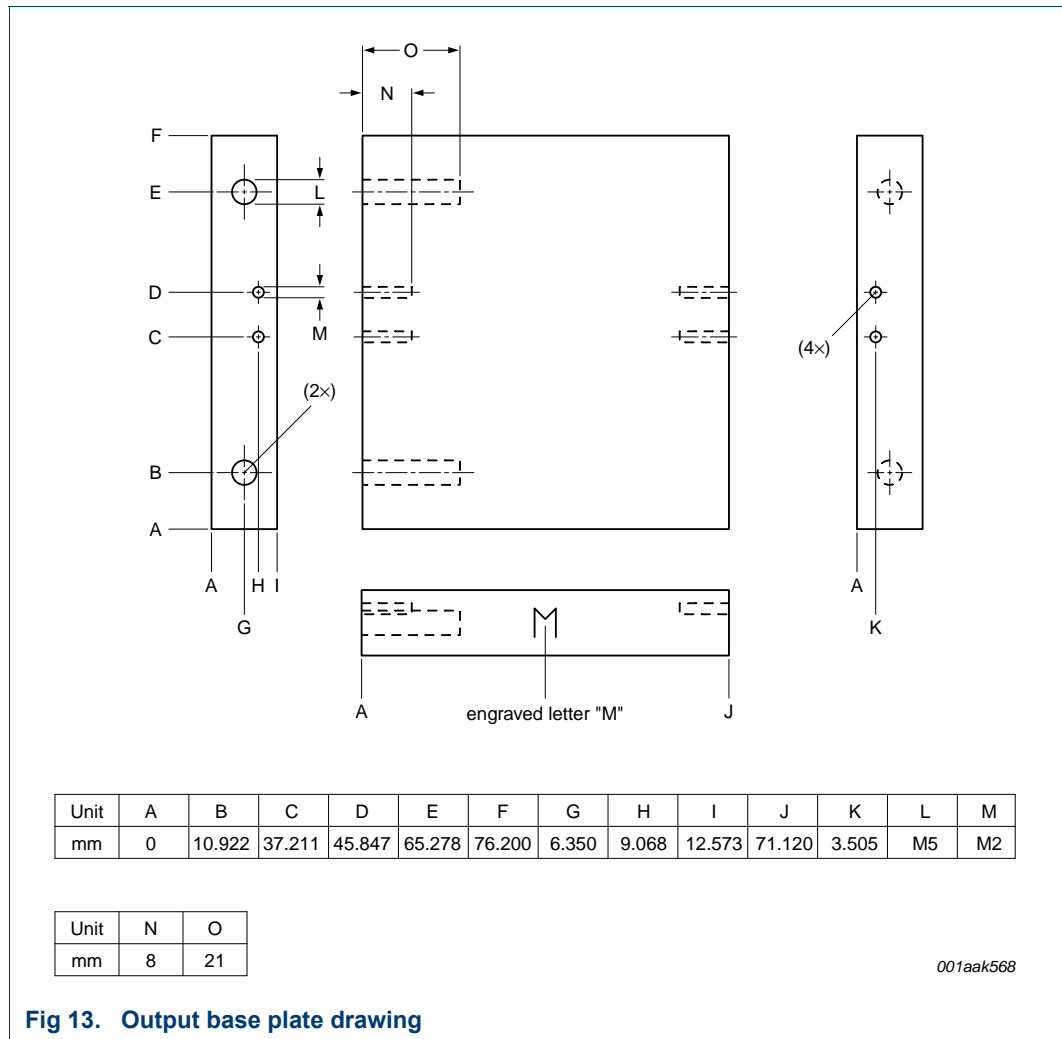

Fig 13. Output base plate drawing

7. Reliability

Time-to-Failure (TTF) is defined as the expected time elapsed until 0.1 % of the devices of a sample size fail. This is different from Mean-Time-to-Failure (MTBF), where half the devices would have failed and its orders of magnitude are shorter. The predominant failure mode for LDMOS devices is electromigration. The TTF for this mode is primarily dependant on junction temperature (T_j) added to the effect of current density. Once the device junction temperature is measured and in-depth knowledge is obtained of the average operating current for the application, the TTF can be calculated using [Figure 14](#) and the related procedure.

7.1 Calculating TTF

The first step uses the thermal resistance (R_{th}) of the device to calculate the junction temperature. The R_{th} from the junction to the device flange for the BLF574 is 0.25 °C/W. If the device is soldered down to the heatsink, this same value can be used to determine T_j . If the device is greased down to the heatsink, the $R_{th(j-h)}$ value becomes 0.4 °C/W.

Example: Assuming the device is running at 600 W with the RF output power at 70 % efficiency on a heatsink (e.g. 40 °C). T_j can be determined based on the operating efficiency for the given heatsink temperature:

- Dissipated power (P_d) = 257 W
- Temperature rise (T_r) = $P_d \times R_{th} = 257 \text{ W} \times (0.4 \text{ °C/W}) = 103 \text{ °C}$
- Junction temperature (T_j) = $T_h + T_r = 40 \text{ °C} + 103 \text{ °C} = 143 \text{ °C}$

Based on this, the TTF can be estimated using a device greased-down heatsink as follows:

- The operating current is just above 17 A
- $T_j = 140 \text{ °C}$

The curve in [Figure 14](#) intersects the x-axis at 17 A. At this point, it can be estimated that it would take 100 years for 0.1 % of the devices to fail.

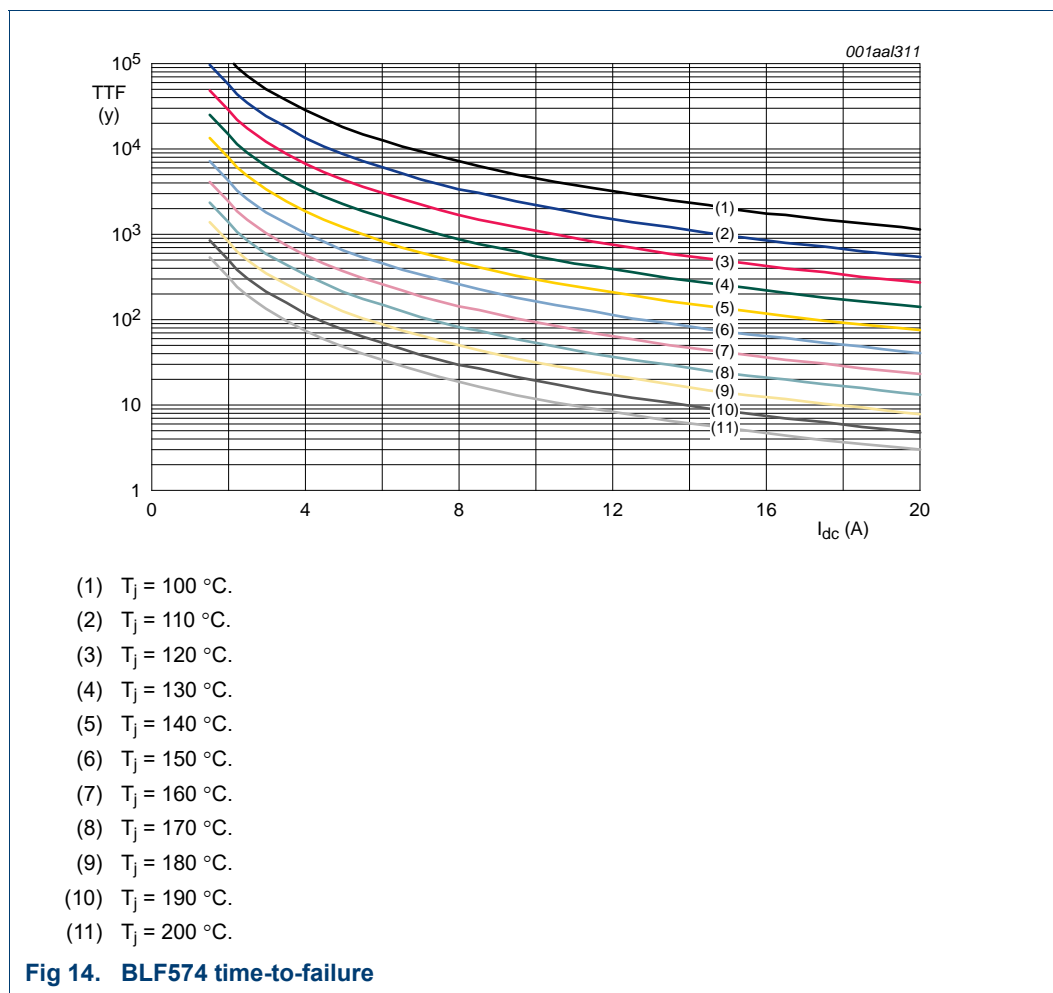

8. Test configuration block diagram

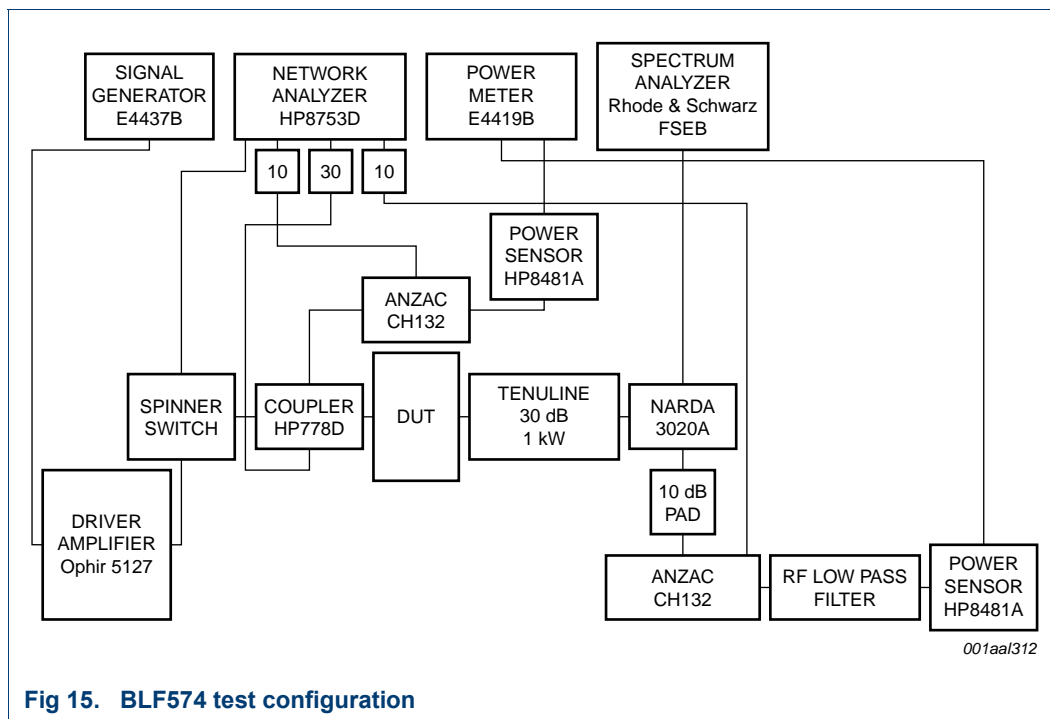

9. PCB layout diagrams

Please contact your local Ampleon salesperson for copies of the PCB layout files.

10. Abbreviations

Table 4. Abbreviations

Acronym	Description
CW	Continuous Wave
ESD	ElectroStatic Discharge
FM	Frequency Modulation
IMD	InterModulation Distortion
IRL	Input Return Loss
LDMOST	Laterally Diffused Metal-Oxide Semiconductor Transistor
PAR	Peak-to-Average power Ratio
PCB	Printed-Circuit Board
SMT	Surface Mount Technology
VHF	Very High Frequency
VSWR	Voltage Standing Wave Ratio

11. Legal information

11.1 Definitions

Draft — The document is a draft version only. The content is still under internal review and subject to formal approval, which may result in modifications or additions. Ampleon does not give any representations or warranties as to the accuracy or completeness of information included herein and shall have no liability for the consequences of use of such information.

11.2 Disclaimers

Limited warranty and liability — Information in this document is believed to be accurate and reliable. However, Ampleon does not give any representations or warranties, expressed or implied, as to the accuracy or completeness of such information and shall have no liability for the consequences of use of such information. Ampleon takes no responsibility for the content in this document if provided by an information source outside of Ampleon.

In no event shall Ampleon be liable for any indirect, incidental, punitive, special or consequential damages (including - without limitation - lost profits, lost savings, business interruption, costs related to the removal or replacement of any products or rework charges) whether or not such damages are based on tort (including negligence), warranty, breach of contract or any other legal theory.

Notwithstanding any damages that customer might incur for any reason whatsoever, Ampleon's aggregate and cumulative liability towards customer for the products described herein shall be limited in accordance with the *Terms and conditions of commercial sale* of Ampleon.

Right to make changes — Ampleon reserves the right to make changes to information published in this document, including without limitation specifications and product descriptions, at any time and without notice. This document supersedes and replaces all information supplied prior to the publication hereof.

Suitability for use — Ampleon products are not designed, authorized or warranted to be suitable for use in life support, life-critical or safety-critical systems or equipment, nor in applications where failure or malfunction of an Ampleon product can reasonably be expected to result in personal injury, death or severe property or environmental damage. Ampleon and its suppliers accept no liability for inclusion and/or use of Ampleon products in such equipment or applications and therefore such inclusion and/or use is at the customer's own risk.

Applications — Applications that are described herein for any of these products are for illustrative purposes only. Ampleon makes no representation or warranty that such applications will be suitable for the specified use without further testing or modification.

Customers are responsible for the design and operation of their applications and products using Ampleon products, and Ampleon accepts no liability for any assistance with applications or customer product design. It is customer's sole responsibility to determine whether the Ampleon product is suitable and fit for the customer's applications and products planned, as well as for the planned application and use of customer's third party customer(s). Customers should provide appropriate design and operating safeguards to minimize the risks associated with their applications and products.

Ampleon does not accept any liability related to any default, damage, costs or problem which is based on any weakness or default in the customer's applications or products, or the application or use by customer's third party customer(s). Customer is responsible for doing all necessary testing for the customer's applications and products using Ampleon products in order to avoid a default of the applications and the products or of the application or use by customer's third party customer(s). Ampleon does not accept any liability in this respect.

Export control — This document as well as the item(s) described herein may be subject to export control regulations. Export might require a prior authorization from competent authorities.

11.3 Trademarks

Notice: All referenced brands, product names, service names and trademarks are the property of their respective owners.

Any reference or use of any 'NXP' trademark in this document or in or on the surface of Ampleon products does not result in any claim, liability or entitlement vis-à-vis the owner of this trademark. Ampleon is no longer part of the NXP group of companies and any reference to or use of the 'NXP' trademarks will be replaced by reference to or use of Ampleon's own Any reference or use of any 'NXP' trademark in this document or in or on the surface of Ampleon products does not result in any claim, liability or entitlement vis-à-vis the owner of this trademark. Ampleon is no longer part of the NXP group of companies and any reference to or use of the 'NXP' trademarks will be replaced by reference to or use of Ampleon's own trademarks.

12. Figures

Fig 1.	BLF574 input circuit schematic; 88 MHz to 108 MHz	4	Fig 8.	Output gain and efficiency comparison for Class-B and Class-AB amplifiers	12
Fig 2.	BLF574 output circuit schematic; 88 MHz to 108 MHz	5	Fig 9.	Second order harmonics as a function of output power against frequency	13
Fig 3.	BLF574 PCB layout	6	Fig 10.	Device impedance convention	14
Fig 4.	Cable length definition	8	Fig 11.	Input base plate drawing	15
Fig 5.	Photograph of the BLF574 circuit board	9	Fig 12.	Device insert drawing	16
Fig 6.	Typical CW data; 88 MHz to 108 MHz	11	Fig 13.	Output base plate drawing	17
Fig 7.	Output gain and efficiency variation under different drain voltage conditions	12	Fig 14.	BLF574 time-to-failure	18
			Fig 15.	BLF574 test configuration	19

13. Contents

1	Introduction	3
2	Circuit diagrams and PCB layout	4
2.1	Circuit diagrams	4
2.2	BLF574 PCB layout	6
2.3	Bill Of Materials	7
2.4	PCB form factor	9
3	Amplifier design	9
3.1	Mounting considerations	9
3.2	Bias circuit	9
3.3	Amplifier alignment	10
4	RF performance characteristics	11
4.1	Continuous wave	11
4.2	Continuous wave graphics	11
5	Input and output impedance	14
6	Base plate drawings	15
6.1	Input base plate	15
6.2	Device insert	16
6.3	Output base plate	17
7	Reliability	17
7.1	Calculating TTF	17
8	Test configuration block diagram	19
9	PCB layout diagrams	19
10	Abbreviations	19
11	Legal information	20
11.1	Definitions	20
11.2	Disclaimers	20
11.3	Trademarks	20
12	Figures	21
13	Contents	21

Please be aware that important notices concerning this document and the product(s) described herein, have been included in section 'Legal information'.

© Ampleon The Netherlands B.V. 2015. All rights reserved.

For more information, please visit: <http://www.ampleon.com>
 For sales office addresses, please visit: <http://www.ampleon.com/sales>

Date of release: 1 September 2015
 Document identifier: AN10714#2